

Installation Manual

PIPE AND EQUIPMENT INSULATION



Contents

(Click below to jump to section)

Safety First	3
Material Handling	3
Preparation and Storage	4
Optimal Work Setup	5
Single Wrap Pipe	6
Double Wrap Pipe	7
Multi-Layer Wrap Pipe	8
Small Bore Pipe	9
Pipe Fittings	10
Valves and Flanges	11
45- and 90-Degree Elbows	15
Installation for Service at Temperature Above 500°C (930°F)	20
Cryogenic Piping and Equipment	21
Filling Cracks and Voids	21
Equipment Procedures	22
Cutting Charts	26

Cryogel® Z and Pyrogel® XT/XT-E 5 mm Blanket Cut Chart (cm), 26
 Cryogel® Z and Pyrogel® XT/XT-E 5 mm (0.2 in) Blanket Cut Chart (inches), 27
 Cryogel® Z and Pyrogel® XT/XT-E 10 mm Blanket Cut Chart (cm), 28
 Cryogel® Z and Pyrogel® XT/XT-E 10 mm (0.4 in) Blanket Cut Chart (inches), 29
 Aerogel Insulation Cladding Cut Chart (mm), 30
 Aerogel Insulation Cladding Cut Chart (inches), 31
 Aerogel Miter Cut Chart (mm), 32-33
 Aerogel Miter Cut Chart (inches), 34-35

Aspen Aerogels® recognizes that performance of our state-of-the-art aerogel insulation materials depends on the total thermal integrity of our system. Therefore, we have developed recommended guidelines for installing Pyrogel® and Cryogel® flexible blanket materials.

All of the procedures described in this manual have been field-proven in conjunction with installation partners.

We are constantly striving to develop new application procedures and insulation systems to make our products stand above our competition with quicker delivery times, simpler logistics, and more reliable installation.

We stand behind our products and are willing to work with you to develop application procedures to suit your project-specific execution plan.

For specialized training or recommendations regarding our application procedures, call 508-691-1111, visit info.aerogel.com/contact, or scan below with mobile device QR reader.



Contact Us

Safety First

Aerogel materials are engineered with safety and performance as our top priorities. Aspen has performed extensive EH&S testing and found our materials to be safe. Our aerogel insulation products are made of amorphous silica impregnated into a non-woven flexible fabric substrate. Amorphous silica is not considered to be a health hazard and, according to the U.S. EPA, "there should be no concerns for human health." The dust from our material is rated by the U.S. Occupational Safety and Health Administration (OSHA) as a "nuisance dust." The silica used in our products is produced synthetically, not mined, and as such contains no crystalline silica.

Handling of aerogel blankets will produce dust. Workplace exposure to all dusts should be controlled with standard industrial hygiene practices. Aerogel dust exposure may produce a sensation of dryness to skin and irritation to eyes, skin, and respiratory track. For worker comfort when working with aerogel, we recommend the use of dust masks, safety eyewear, and work gloves. Aerogel dust can be washed from the skin and clothing using soap and water. Please follow the recommended safety and handling guidelines outlined in our Safety & Handling Guidelines manual, which is available on request. For complete health and safety information, please see our MSDS sheets.

Material Handling

Aerogel insulations when shipped in full rolls are typically 1.5 m (60 in) wide weighing up to 180 kg (400 lb) per roll. Rolls can be moved manually with the use of a metal pipe or wooden 2x4 placed through the center of the roll and picked up from either end, or by using a pallet jack or forklift. Rolls can also be purchased in crates. Rolls should always be placed or stacked on their sides and should never be positioned upright on their ends as this may damage the exposed ends of the roll.



Preparation and Storage

Aerogel insulation materials should be stored in a clean, dry and protected environment. If material is stored in an outdoor setting, it should be placed on pallets and thoroughly covered with a waterproof tarp or plastic sheeting. Although the aerogel material is hydrophobic, all necessary measures should be taken to protect it from the weather.

To prepare for installation:

- Ensure that pressure testing of piping and fittings has been completed prior to installing insulation.
- Ensure that all pipe and fitting surfaces over which insulation is to be installed are clean and dry.
- Ensure that insulation is clean, dry, and in good mechanical condition. Wet, dirty, or damaged insulation is not acceptable for installation.
- Determine pipe size, pipe length, and number of layers of aerogel blanket required for the application. Do not apply Pyrogel material to live equipment or piping (e.g. hot install) while the system is operating above 500°C (930°F). See High-Temperature Installation section on page 20 for more details on high-temperature installations.

NOTE: More information on above sections can be found in our Safety & Handling Guidelines manual, which is available on request.

Optimal Work Setup

To achieve the most productive work environment for use with aerogel insulations we suggest the following setup.

BULK CUTTING AREA

This area will be used for cutting aerogel materials from full rolls into lengths required for the application, as well as cutting any preformed parts required to ease the installation process. This area should be setup in a covered and protected area. This area should contain several tables to accommodate the roll width and cutting length required for each component being worked. The roll of aerogel material should be located at the front of the table where it can be placed on a roller rack with a tube placed through the roll. Please refer to the Recommended Cutting Tools chart below for suggested tools for this application. Parts should be placed on pallets and covered, bagged, or wrapped in plastic before bringing to work area.



WORK AREA

Ideally the material should be placed as close to the work area as possible. Remove the materials from the packaging and distribute to the work location. Please refer to the cutting tools chart below for suggested tools for field applications.

Material	Cutting Tool (FIELD or SHOP)							
	Scissors	Box Cutter	Pizza Wheel/ Electric	Tin Snips	Slitter	Hand Shear	Heated Knife	Dremel Oscillating Tool With MM430 blade
Pyrogel®	FIELD	FIELD	FIELD	FIELD	SHOP	SHOP		
Cryogel®	FIELD	FIELD	FIELD		SHOP		SHOP	SHOP

Single Wrap Pipe

1. Cut aerogel blanket to the length required for a complete wrap. The cut length may be determined by either wrapping a scrap piece around the pipe and marking the place where it overlaps, or consulting the cutting charts on pages 26-35. Either a butt joint or lap joint is acceptable for the longitudinal seam.

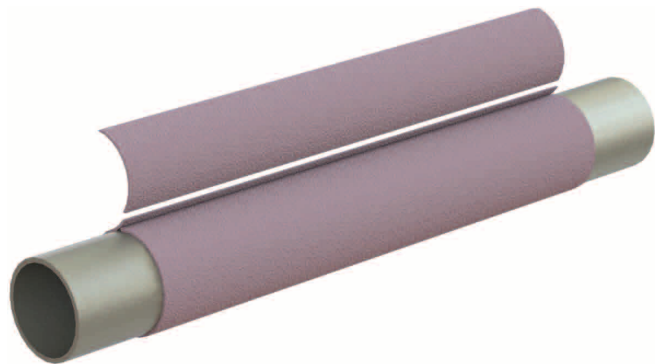

2. Place the aerogel on the pipe and wrap around the circumference of the pipe. The starting edge of the aerogel can be held in place by hand or with a strip of spray adhesive. The use of spray adhesives is limited to application temperatures below 250°C (480°F), and should never be used on live, operating equipment.



3. Once wrapped around the pipe, the aerogel may be held in place using tape, wire, adhesive spray, or banding. The use of tape and spray adhesives is limited to application temperatures below 250°C (480°F).

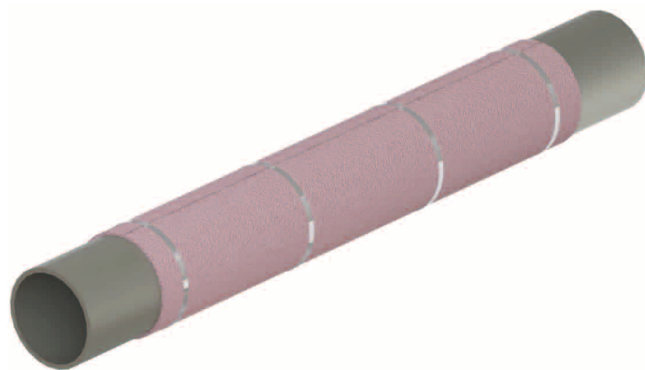

4. Completed assembly showing lap joint. It is good practice to orient the overlap with a downward-facing watershed.



Double Wrap Pipe

1. Cut the aerogel blanket to the length required for a complete wrap. The cut length may be determined by either wrapping a scrap piece around the pipe and marking the place where it overlaps, or consulting the cutting charts on pages 26-35. Either a butt joint or lap joint is acceptable for the longitudinal seam.



2. Align the leading edge of the aerogel with the long axis of the pipe and wrap around the pipe. The starting edge of the aerogel can be held in place by hand or with a strip of spray adhesive. The use of spray adhesives is limited to application temperatures below 250°C (480°F), and should never be used on live, operating equipment.

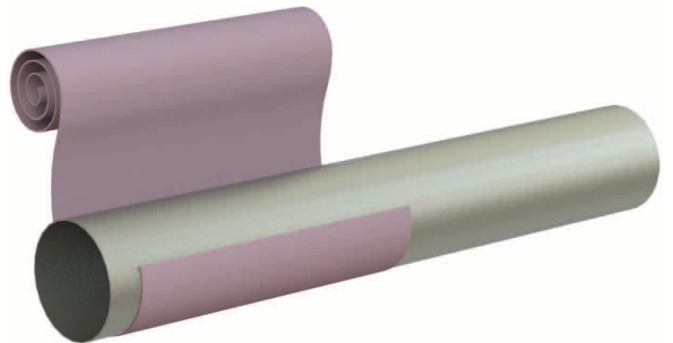

3. Overlap and continue around the circumference to achieve the double-layer application.

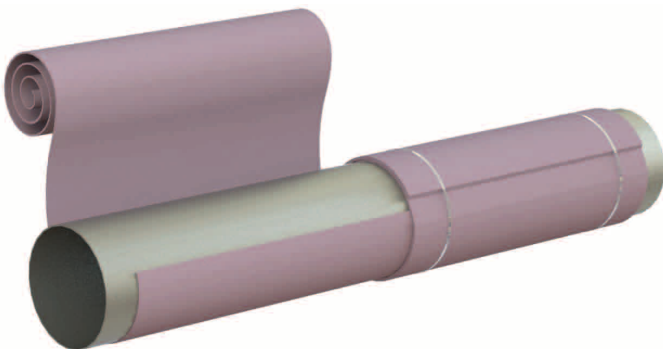

4. Once wrapped around the pipe, the aerogel may be held in place using tape, wire, adhesive spray, or banding. The use of tape and spray adhesives is limited to application temperatures below 250°C (480°F).

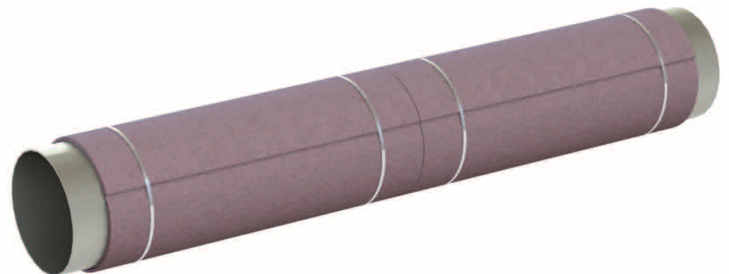

5. Install metal cladding in typical fashion and seal with owner-approved sealant.

Multi-Layer Wrap Pipe

1. For applications that require the use of more than two layers of aerogel blanket, the suggested procedure follows the same steps as the double-layer application, overlapping the circumferential and longitudinal joints.

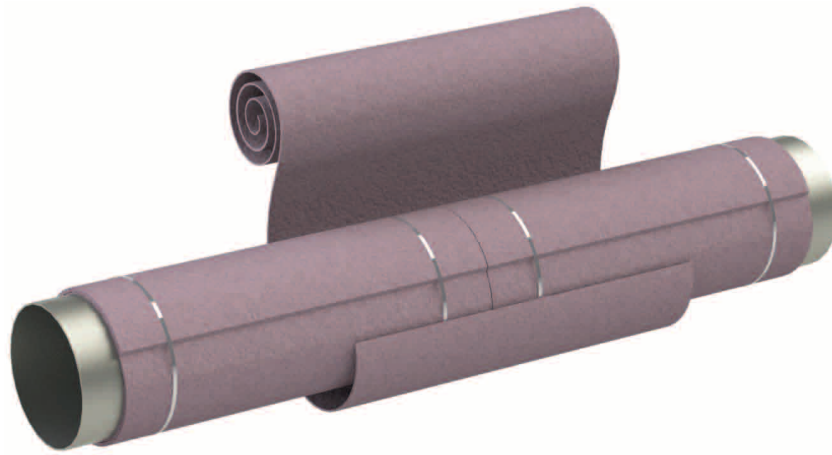

2. Once wrapped around the pipe, the aerogel may be held in place using tape, wire, adhesive spray, or banding. The use of tape and spray adhesives is limited to application temperatures below 250°C (480°F).

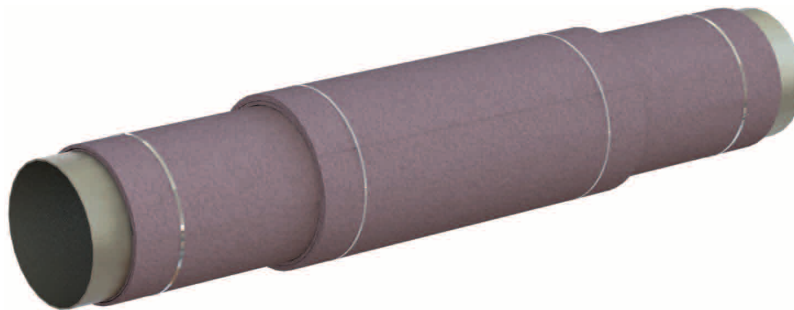

3. Install metal cladding in typical fashion and seal with owner-approved sealant.



Small Bore Pipe - 15 to 100 mm (1/2 to 4 in) NPS

For piping smaller than 100 mm (4 in) NPS, we suggest the use of V-grooved, cut-to-length materials. Another option is to use 5 mm (0.2 in) materials, as they are more flexible than their 10 mm (0.4 in) counterparts. This can be either wrapped in the traditional fashion, or spiral wound onto the pipe with a 50% overlap. Contact Aspen Aerogels at 508-691-1111 or info.aerogel.com/contact for details on local suppliers of pre-fabricated elbows and accessories.

V-GROOVE

- 1.** V-grooved pipe cover comes pre-cut to the particular pipe size and insulation thickness so that each layer comes to a perfect, butted closure.
- 2.** For multi-layer applications, align the grooves for better laydown, but stagger the longitudinal seams.



SPIRAL WRAP

- 1.** For spiral-wrap installation, strip materials should generally be 5 mm (0.2 in) thick, 50 to 75 mm (2 to 3 in) wide, and provided in rolls measuring 3 to 7.5 m (10 to 25 ft) long.
- 2.** Place the end of the aerogel strip on the pipe and wrap around the circumference of the pipe, overlapping each wrap by 50 percent in a corkscrew pattern. The beginning of the strip can be held in place by hand, or with spray adhesive, tape, or wire.
- 3.** Once wrapped around the pipe, the aerogel may be held in place using tape, wire, or adhesive spray.
- 4.** Repeat this same procedure for subsequent layers.
- 5.** Cladding should be installed in typical fashion. Note that small-bore pipe insulated with aerogel can have a finished diameter that is smaller than most sheet metals can be mechanically rolled. In these cases, the curvature of the jacketing can be tightened by hand. Alternatively, non-metallic jacketings (VentureClad, Fibaroll/Fibaclad, Ulva, etc.) can be used, subject to owner's approval.

Pipe Fittings

PIPE ENDS

Install the aerogel blanket past the pipe end to the same distance as required for the thickness of the insulation.

Cut plugs from the aerogel to the diameter of the opening and install to match the thickness.

REDUCERS

Install the aerogel blanket to the same thickness as would be required for the piping using the same layout pattern as would be required for the metal cladding less the required overlaps.

Install each layer in a staggered fashion.

TEES

Install the aerogel blanket using the same techniques as would be used for installing the cladding. Contact Aspen Aerogels at 508-691-1111 or info.aerogel.com/contact for details on local suppliers of pre-cut tees.



PIPING SHOES

Install the aerogel blanket around the pipe adjacent to the pipe shoe and make a slit the length of the shoe.

Slide aerogel through the shoe area and continue wrapping the aerogel on the other end of the shoe area.

For some shoe types that have a welded section through the center, it may be necessary to apply aerogel from both ends.

Contact Aspen Aerogels at 508-691-1111 or info.aerogel.com/contact for details on local suppliers Pyrogel® and Cryogel® insulated pipe shoes.

Valves and Flanges

This section gives the general techniques for insulating valves. Because of the variety in valves shapes and designs, some modifications to these instructions may be necessary.

- 1.** Unless the finished aerogel thickness could obstruct the bolt pattern on the flange, insulate the pipe all the way up to the flange face.
- 2.** Wrap a strip of aerogel over the insulated pipe portion to achieve the same diameter as the flange.
- 3.** Cut the disc to the same size as the bonnet end if insulation is required on the bonnet section.

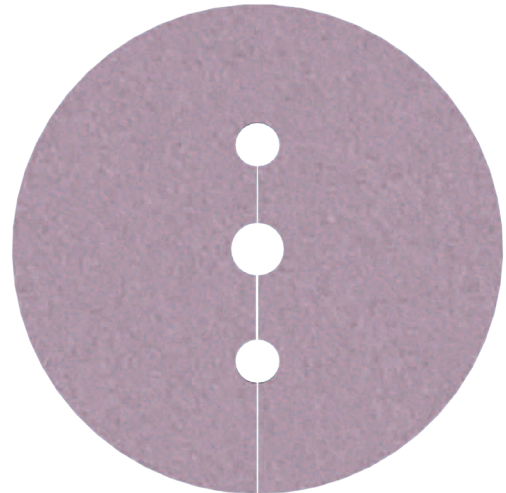
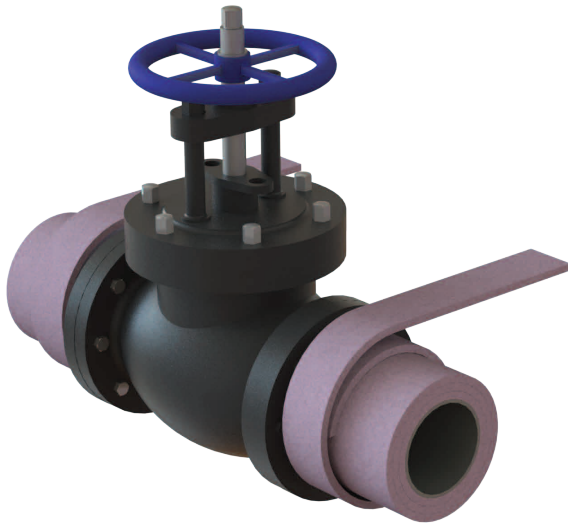

- 4.** Measure the distance between the two outer faces of the aerogel strips.

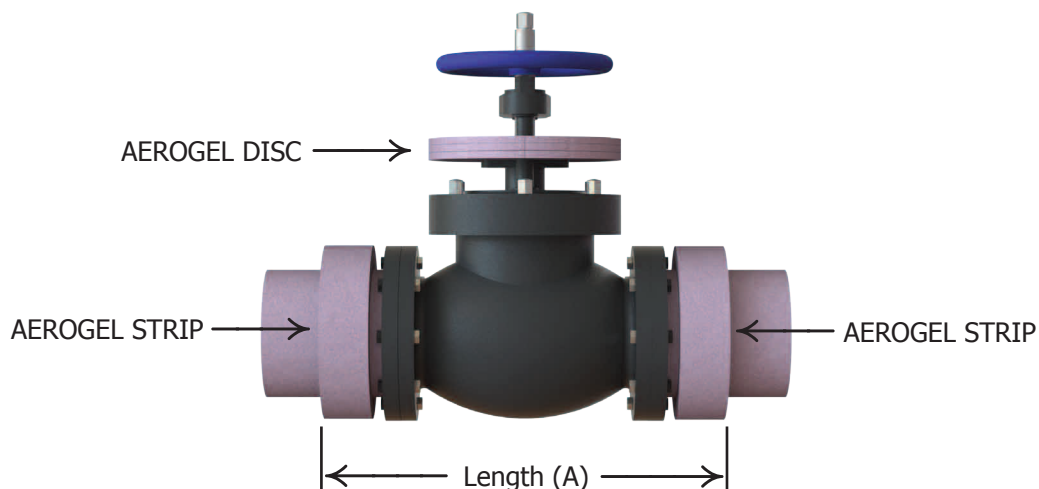

Valves and Flanges

5. Transfer length "A" and circumference "B" to aerogel sheet and mark the cutouts for the bonnet neck "C". Move the cutout on each wrap of aerogel to achieve stagger, and slide over handle section to achieve stagger. Note: on installations above 500°C (930°F), pack void spaces with Pyrogel® or high-density (96 kg/m³ or 6 lb/ft³) ceramic fiber. See High-Temperature Installation section on page 20.

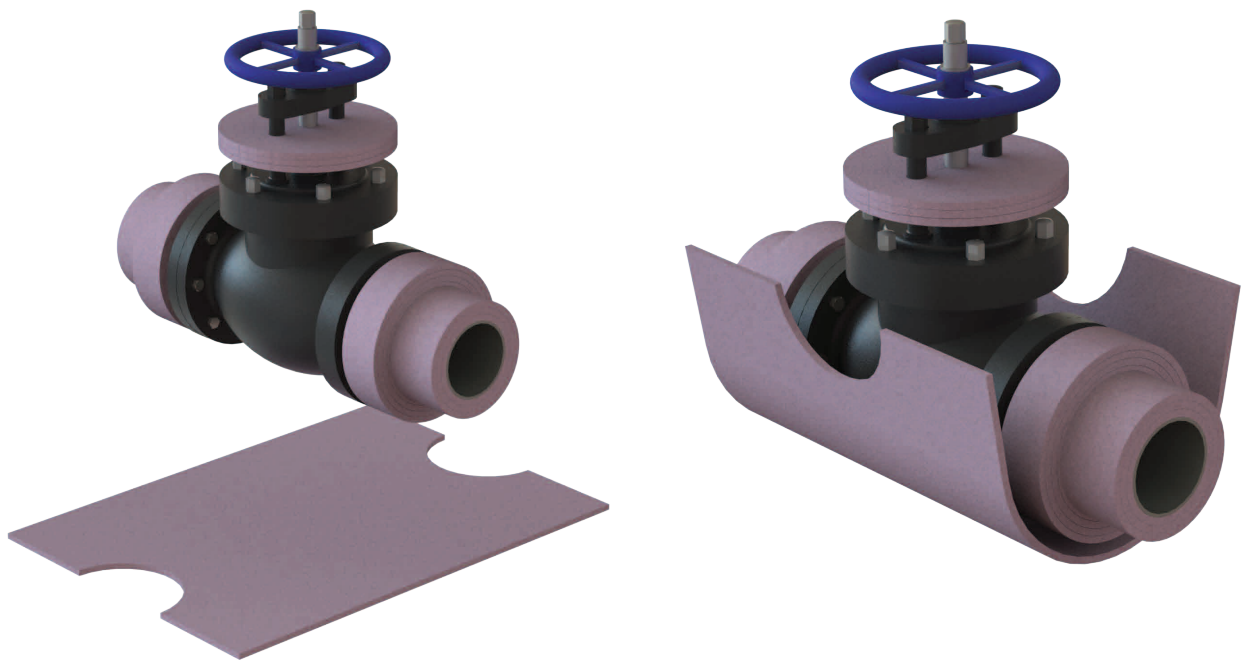
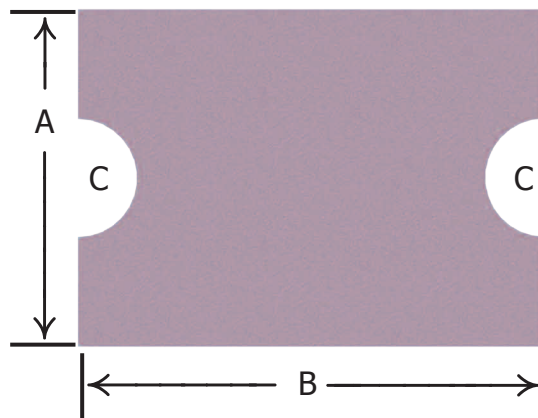

6. The aerogel sheet is now wrapped around the valve body followed by any additional layers with joints staggered. Attachment of the aerogel may be done with tape, wire, adhesive spray, or banding.

Valves and Flanges

7. The last pieces will insulate the bonnet area if required. The bonnet insulation of aerogel is cut to the size of $C \times L1$, then marked in quarters. Next, the scalloped edge of the insulation is determined by swinging an arc from each point marked +. The radius of the arc is equal to Y . These areas are connected with straight lines to give a smooth scalloped edge.

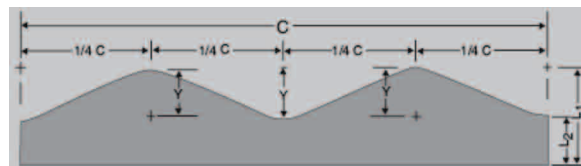
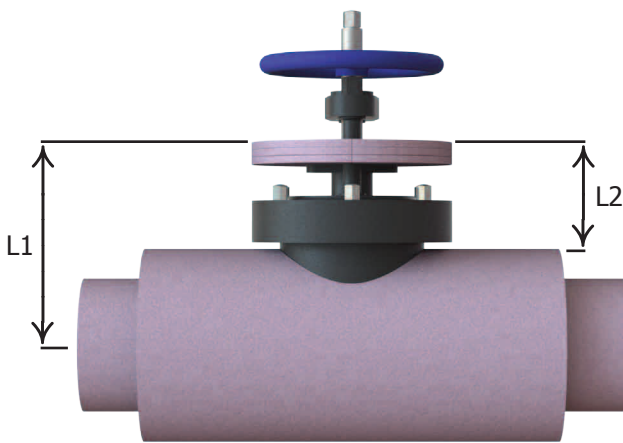

C	Overall length determined by wrapping a strip of aerogel around the bonnet flange and marking where the ends meet
L1	Distance is from the outer surface of the aerogel disc to the approximate middle of the valve body insulation
L2	Distance is from the outer surface of the aerogel disc to the closest surface of the valve body insulation
Y	Difference between L1 and L2

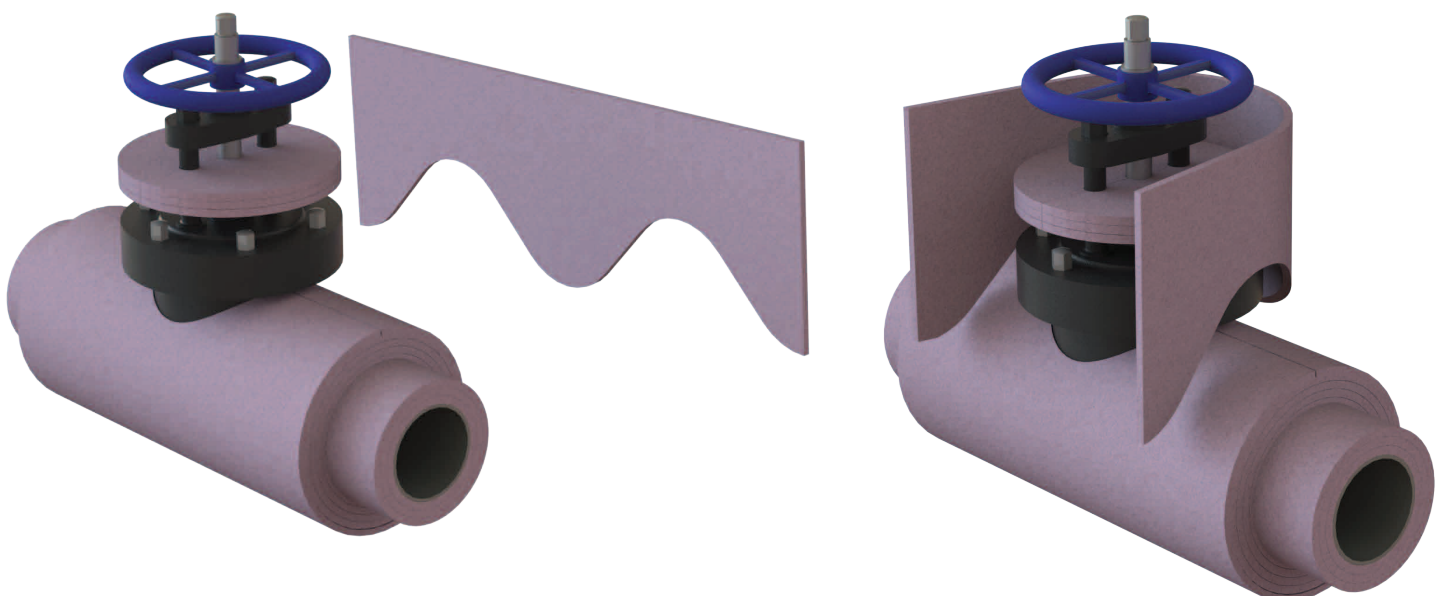

Valves and Flanges

8. Once installation of the aerogel insulation layers is complete, the finished valve should resemble below.

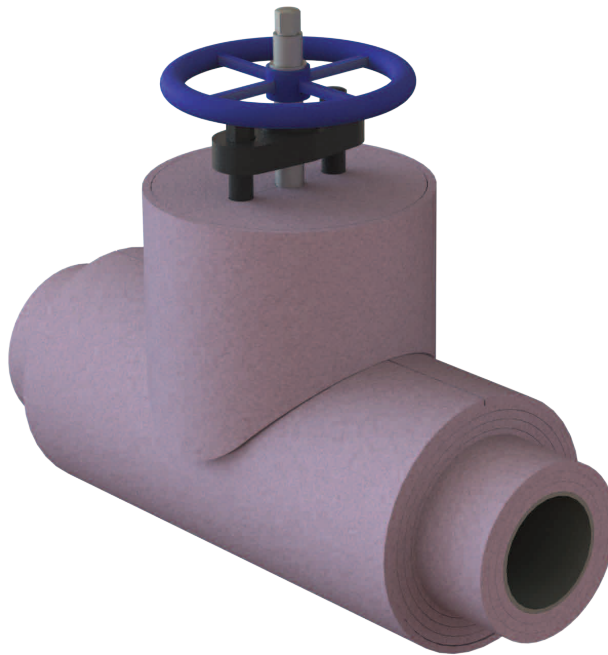

9. Install metal cladding over aerogel and seal with specification-approved sealant.

10. Aerogel-lined removable metal or blanket covers may also be an option for valves and flanges. When operating temperature is greater than 500°C (930°F), the inner layers of insulation shall be encapsulated with stainless steel foil.



45- and 90-Degree Elbows

Suggested Elbow Chart				
Pipe Size (NPS)		Elbow Type		
mm	inches	Pre-Cut	Gored	Stove Pipe
15 – 40	1/2 – 1 1/2	√		√
50 – 150	2 – 6	√	√	
200 – 300	8 – 12	√	√	
350 – 600	14 – 24	√	√	
650 – 900	26 – 36	√	√	
950 – 1,200	38 – 48	√	√	

The instructions on the following pages cover three types of elbows available for use with aerogel materials and installation suggestions.

Contact Aspen Aerogels at 508-691-1111 or info.aerogel.com/contact for details on local suppliers of pre-fabricated elbows and accessories.

45- and 90-Degree Elbows

SINGLE-PIECE ELBOW FITTINGS

Pre-fabricated elbows for piping NPS 200 mm (8 in) and smaller are based on a reverse gore-style pattern that gathers in the throat and is closed along the heel. Larger elbows are constructed of individual gores that get applied one at a time in the field, with the seam located in the throat.

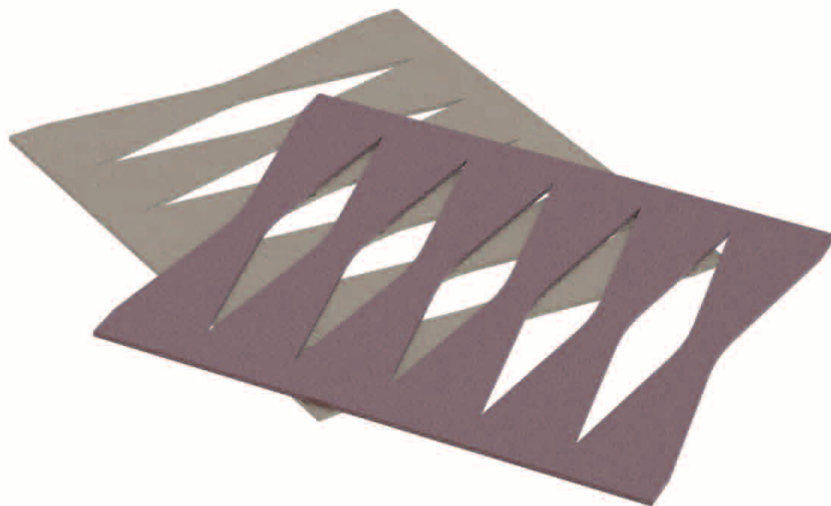

1. Place the middle of the fitting along the inside (throat) of the pipe fitting.



45- and 90-Degree Elbows

2. Tightly wrap material around to the heel, aligning the seam with the centerline of the fitting.



3. It is important that the aerogel material is tight to the elbow. Work excess material around the fitting towards the back side of the fitting until the butt joint is closed tightly. Apply tape, wire, or outward-clenching staples to secure each finger.



45- and 90-Degree Elbows

4. Once all fingers have been secured, push material from both ends of the fitting cover to ensure all gore seams are tightly closed.

5. Apply all subsequent layers in a similar fashion. Note that the seams in some layers are specifically engineered to not line up with the ones beneath it. Also note that in multi-layer fittings, the inner layers will often have an extended tangent to provide a ship-lap joint for the adjacent line insulation.

6. Install metal cladding and seal with specification-approved sealant.



45- and 90-Degree Elbows

GORED ELBOW FITTINGS

This style of elbow can be cut by the contractor using the same principles that are used to fabricate metal gored elbow, minus the overlaps.

Cut the aerogel blanket to the required length and cut as per the gore pattern. Install each layer, staggering the seams where possible. This can be achieved by slitting one of the gored sections down the center to create half a gore. This half section will be used for the starter and finisher of the staggered layer. The gored elbow may also be achieved by separating the pre-cut elbows and installing one gore at a time.

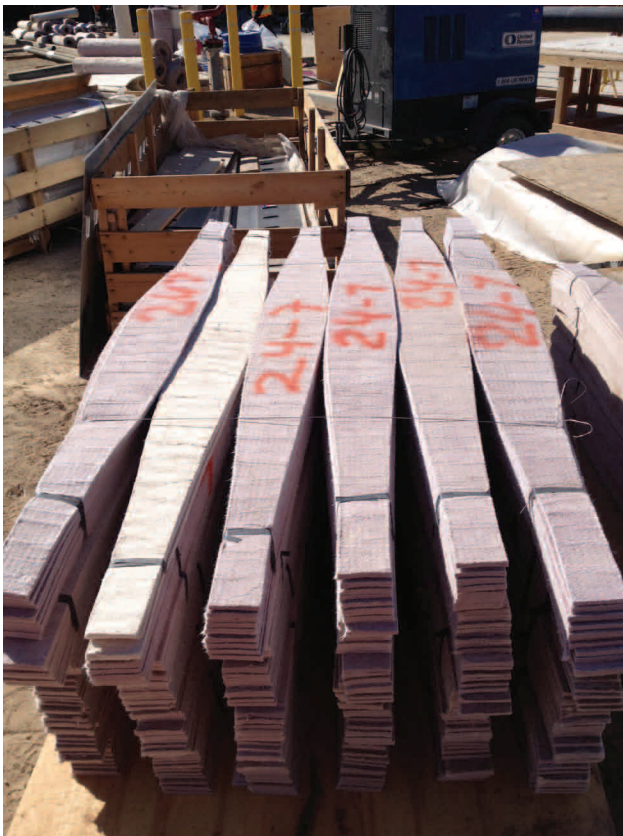

STOVE PIPE

We recommend that this style of elbow only be used on small bore piping where the fabrication of the above elbow styles can not be done due to limited elbow throat space. In order to fabricate this elbow, we recommend that the pre-formed pipe covering be cut at a 45-degree angle with the sections adjoined in the elbow to form the 90-degree elbow.

Installation for Service at Temperature Above 500°C (930°F)

All hot insulation materials can experience self-heating behavior when first exposed to conditions near their maximum use temperature. This usually occurs as organic ingredients or contaminants within or on the material oxidize and give off heat, raising the insulation's internal temperature and resulting in yet more oxidation. In extreme cases, this thermal feedback loop can result in uncontrolled burn-in and damage to the material, including shrinkage, cracking, and loss of hydrophobicity.

To keep self-heating behavior within a range of acceptability (as defined by the standards of ASTM C447¹ and ASTM C1728²), the installation instructions below must be followed:

- Install insulation tightly, with no visible gaps between layers.
- On installations above 250°C (480°F), do not use tapes and/or any organic adhesives. Metallic fasteners (e.g., wire, bands, staples) are acceptable.
- On complex shapes (e.g., valves, flanges, turbine bodies) or vertical configurations, interleave stainless steel foil between one or more layers of Pyrogel[®] to block airflow.
- Pack void spaces (e.g., around valve bodies and flanges) to prevent the formation of chimneys. Pyrogel[®] or high-density >96 kg/m³ (6 lb/ft³) ceramic fiber are both suitable fill materials.
- Metallic jacketing is required, and must be installed and sealed completely before start-up.
- Do not remove or disturb the jacketing or insulation during startup.
- Do not apply Pyrogel[®] to live equipment or piping (i.e., "hot installs") while in operation above 500°C (930°F).

1. ASTM C447-03, "Standard Practice for Estimating the Maximum Use Temperature of Thermal Insulations," ASTM International, West Conshohocken, PA, USA.

2. ASTM C1728-13, "Standard Specification for Flexible Aerogel Insulation," ASTM International, West Conshohocken, PA, USA.

Cryogenic Piping and Equipment

Follow the application procedures in the previous sections for piping, fittings, valves and flanges, and elbows. On an n-layer system (where $n > 3$), layering shall be as follows:

↑ Inner Surface	Pipe
	Cryogel layer 1
	⋮
	Cryogel layer n-3
	Cryogel layer n-2
	Secondary vapor barrier: all seams taped
	Cryogel layer n-1
↓ Outer Surface	Metal bands
	Cryogel layer n
	Primary vapor barrier: sheet membrane or mastic
	Apply weather barrier jacketing and bands (as necessary)

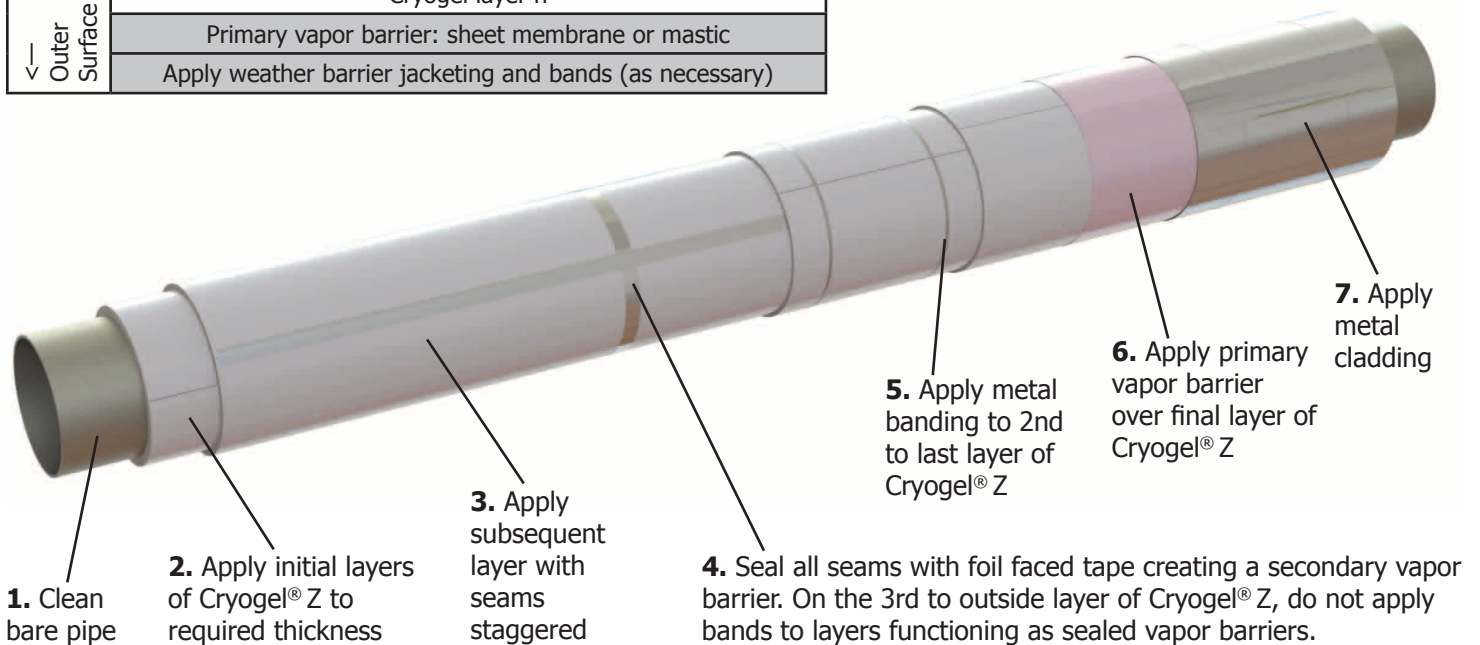

Filling Cracks and Voids

Filling small cracks and voids can be achieved by delaminating the Cryogel® Z to a workable thickness and pushing it into the crack with the use of a knife. For larger cracks and voids, it is recommended that strips or sections be cut from a blanket and added. When delaminating, take care not to shred the material causing it to loosen the aerogel material from the section. It is not recommended that it be shredded into fiber in order to do this, as this will cause the loss of aerogel from the material.

Equipment Procedures

This section covers the installation of aerogel insulation for tanks and vessels. Because of the variety in shape and design of tanks and vessels, some modifications to these instructions may be necessary. The following application procedures are intended to be used as a guideline and are not intended to act as the only form of installation.

PREPARATION

Ensure that pressure testing of equipment has been completed prior to installing insulation.

Ensure that all equipment surfaces over which insulation is to be installed are clean and dry.

Ensure that insulation is clean, dry, and in good mechanical condition. Wet, dirty, or damaged insulation is not acceptable for installation. Do not apply to live equipment while in operation above 500°C (930°F).

STANDARD INSULATION PROCEDURES

- 1.** Determine the area to be insulated. Calculate the circumference of the tank or vessel based on the outside of the insulation.
- 2.** Cut the aerogel insulation to the desired working length. For smaller tanks or vessels, we suggest a continuous wrap per layer. For larger tanks or vessels, we suggest cutting the aerogel insulation to the length that will be workable for the work area.
- 3.** Attach the leading edge of the aerogel insulation with welded or self-adhesive insulation pins. Apply clips and wrap the insulation around the circumference of the tank or vessel. If the use of pins is not possible, the aerogel material can be held in place with bungee-type straps or a light pass of chloride-free spray adhesive until the wrap is completed and metal banding can be applied.
- 4.** Install welded or self-adhesive pins to the end location adjacent the leading edge, and press over pins and apply clips.
- 5.** For cutouts, we suggest cutting a slit in the aerogel insulation and sliding it into position. Then trim to fit the location using a sharp knife or scissors.
- 6.** Apply banding around the circumference of the tank or vessel and tighten. Band springs may be required where specified.
- 7.** Install metal cladding and seal with specification-approved sealant.

NOTE: When installing multiple layers of aerogel insulation, staggering the edges is recommended.

Equipment Procedures

VESSEL HEAD INSTALLATION

Cut the aerogel insulation in a wedge shape using these methods. Because of the flexibility of aerogel material, the large edge at the tangent line of the section may be much larger than normally applied with other insulation products.

Field Cut Method

1. Measure the distance from the tangent line to the center of the head.

2. Cut the aerogel material to the length as measured from tangent line to head center.

3. Cut the aerogel material to the desired width at the tangent line. Mark both edges back to the center line at the other edge of the material, creating a wedge shape.

4. Attach aerogel material at the center point for the head using insulation weld or stick pins. Pull back to the tangent line, and attach with the same method at this location. If the use of pins is not an option, this can be done with the use of a choker system around the tangent line with wire or banding pulled over the installed wedge section to hold it in place.



5. Continue installing the same size wedge sections at each quarter of the head section. Fill in the remaining sections with the same size pieces until they will no longer fit. At this point trimming the pieces will be required to fit in the sections that are now existing.

6. Install metal cladding and seal with specification-approved sealant.

Equipment Procedures

VESSEL HEAD INSTALLATION

Shop Cut Method

- 1.** Measure the distance from the tangent line to the center of the head.
- 2.** Cut the aerogel material to the length as measured from tangent line to head center.
- 3.** Determine circumference on the outside of the aerogel material.
- 4.** Determine the desired working size of the material at the tangent line, and divide by the circumference to determine the required pieces.
- 5.** Determine the center point of the head, and divide by the number of required pieces.
- 6.** With the determined measurements of the tangent line and center section, mark these on the sheet one at each end, and cut the required amount.
- 7.** Attach the aerogel material at the center point for the head using insulation weld or stick pins. Pull back to the tangent line, and attach with the same method at this location. If the use of pins is not an option, this can be done with the use of a choker system around the tangent line with wire or banding pulled over the installed wedge section to hold in place.
- 8.** Install metal cladding and seal with specification-approved sealant.



Equipment Procedures

TRANSITIONS AND CONES

1. Determine the length of the sloped surface.
2. Cut the aerogel material to the determined length.
3. Determine the circumference of the vessel or tank.
4. Divide the circumference by the desired work width of aerogel material to determine the number of pieces required.
5. Determine the circumference at the bottom of the cone.
6. Mark each end of the cut aerogel material and cut into a wedge shape.
7. Attach the aerogel material at the center point for the cone using insulation weld or stick pins. Pull back to the tangent line, and attach with the same method at this location. If the use of pins is not an option, this can be done with the use of a choker system around the tangent line with wire or banding pulled over the installed wedge section to hold it in place.
8. Install metal cladding to required specifications and seal with specification approved sealant.



Cryogel® Z and Pyrogel® XT/XT-E 5 mm Blanket Cut Chart (cm)

Material Stretchout (cm)												
NIPS (mm)	Number of Layers											
	1	2	3	4	5	6	7	8	9	10	11	12
15	12.6	25.9	42.6	62.7	86.0	112.7	142.7	176.0	212.7	252.7	296.1	342.7
20	14.2	29.3	47.7	69.4	94.4	122.7	154.4	189.5	227.8	269.5	314.5	362.8
25	16.4	33.5	54.0	77.8	105.0	135.4	169.2	206.4	246.8	290.6	337.8	388.2
32	19.1	39.0	62.3	88.8	118.7	151.9	188.5	228.4	271.6	318.2	368.0	421.2
40	21.0	42.9	68.0	96.5	128.3	163.4	201.9	243.7	288.8	337.3	389.1	444.2
50	24.8	50.4	79.4	111.6	147.2	186.2	228.4	274.0	323.0	375.2	430.8	489.7
65	28.8	58.4	91.3	127.6	167.2	210.1	256.4	306.0	358.9	415.1	474.7	537.6
80	33.8	68.4	106.3	147.6	192.1	240.0	291.3	345.9	403.8	465.0	529.5	597.4
90	37.8	76.4	118.3	163.5	212.1	264.0	319.2	377.8	439.7	504.9	573.4	645.3
100	41.8	84.3	130.2	179.5	232.0	287.9	347.1	409.7	475.6	544.8	617.3	693.2
115	45.8	92.3	142.2	195.4	252.0	311.9	375.1	441.6	511.5	584.7	661.2	741.1
125	50.3	101.3	158.2	213.4	274.4	338.8	406.5	477.5	551.9	629.6	710.6	795.0
150	58.7	118.3	183.1	247.3	316.8	389.7	465.8	545.3	628.2	714.3	803.8	896.7
200	74.7	150.2	232.9	311.1	396.6	485.4	577.6	673.0	771.8	873.9	979.4	1088.2
250	91.7	184.1	283.0	379.0	481.4	587.2	696.3	808.7	924.4	1043.5	1165.9	1291.7
300	107.6	216.0	331.2	442.8	561.2	682.9	808.0	936.3	1068.1	1203.1	1341.5	1483.2
350	117.6	236.0	361.2	482.7	611.1	742.8	877.8	1016.1	1157.8	1302.8	1451.2	1602.9
400	133.5	267.9	409.2	546.5	690.9	838.5	989.5	1143.8	1301.5	1462.4	1626.7	1794.4
450	149.5	299.8	456.9	610.4	770.7	934.3	1101.2	1271.5	1445.1	1622.0	1802.3	1985.9
500	165.5	331.7	505.0	674.2	850.5	1030.0	1212.9	1399.2	1588.7	1781.6	1977.8	2177.4
550	181.4	363.6	552.7	738.0	930.3	1125.8	1324.6	1526.8	1732.4	1941.2	2153.4	2368.9
600	197.4	395.6	600.7	801.9	1010.0	1221.5	1436.4	1654.5	1876.0	2100.8	2329.0	2560.4
650	213.3	427.5	648.5	865.7	1089.8	1317.3	1548.1	1782.2	2019.6	2260.4	2504.5	2751.9
700	229.3	459.4	696.5	929.6	1169.6	1413.1	1659.8	1909.9	2163.3	2420.0	2680.1	2943.4
750	245.3	491.3	744.2	993.4	1249.4	1508.8	1771.5	2037.5	2306.9	2579.6	2855.6	3135.0
800	261.2	523.2	792.2	1057.2	1329.2	1604.6	1883.2	2165.2	2450.5	2739.2	3031.2	3326.5
850	277.2	555.1	840.0	1121.1	1409.0	1700.3	1994.9	2292.9	2594.2	2898.8	3206.7	3518.0
900	293.1	587.1	888.0	1184.9	1488.8	1796.1	2106.7	2420.6	2737.8	3058.4	3382.3	3709.5
950	309.1	619.0	935.7	1248.7	1568.6	1891.8	2218.4	2548.2	2881.4	3218.0	3557.8	3901.0
1000	325.1	650.9	983.7	1312.6	1648.4	1987.6	2330.1	2675.9	3025.1	3377.6	3733.4	4092.5
1050	341.0	682.8	1031.5	1376.4	1728.2	2083.3	2441.8	2803.6	3168.7	3537.1	3908.9	4284.0
1100	357.0	714.7	1079.5	1440.3	1808.0	2179.1	2553.5	2931.3	3312.3	3696.7	4084.5	4475.5
1150	372.9	746.7	1127.3	1504.1	1887.8	2274.9	2665.2	3058.9	3456.0	3856.3	4260.0	4667.1
1200	388.9	778.6	1175.3	1567.9	1967.6	2370.6	2776.9	3186.6	3599.6	4015.9	4435.6	4858.6

NOTES:

Includes 2.5 cm (1 in) overlap.

All measurements should be verified with a test piece.

Contact Aspen Aerogels for additional sizes.

Cryogel® Z and Pyrogel® XT/XT-E 5 mm (0.2 in) Blanket Cut Chart (inches)

Material Stretchout (inches)												
NPS (inches)	Number of Layers											
	1	2	3	4	5	6	7	8	9	10	11	12
0.5	4.9	10.2	16.8	24.7	33.9	44.4	56.2	69.3	83.7	99.5	116.6	134.9
0.75	5.6	11.5	18.8	27.3	37.2	48.3	60.8	74.6	89.7	106.1	123.8	142.8
1	6.4	13.2	21.3	30.6	41.3	53.3	66.6	81.2	97.2	114.4	133.0	152.8
1.25	7.5	15.4	24.5	35.0	46.7	59.8	74.2	89.9	106.9	125.3	144.9	165.8
1.5	8.3	16.9	26.8	38.0	50.5	64.3	79.5	96.0	113.7	132.8	153.2	174.9
2	9.8	19.9	31.3	44.0	58.0	73.3	89.9	107.9	127.1	147.7	169.6	192.8
2.5	11.3	23.0	36.0	50.2	65.8	82.7	100.9	120.5	141.3	163.4	186.9	211.6
3	13.3	26.9	41.9	58.1	75.6	94.5	114.7	136.2	159.0	183.1	208.5	235.2
3.5	14.9	30.1	46.6	64.4	83.5	103.9	125.7	148.7	173.1	198.8	225.8	254.1
4	16.4	33.2	51.3	70.7	91.4	113.4	136.7	161.3	187.2	214.5	243.0	272.9
4.5	18.0	36.3	56.0	76.9	99.2	122.8	147.7	173.9	201.4	230.2	260.3	291.8
5	19.8	39.9	62.3	84.0	108.0	133.4	160.0	188.0	217.3	247.9	279.8	313.0
6	23.1	46.6	72.1	97.4	124.7	153.4	183.4	214.7	247.3	281.2	316.5	353.0
8	29.4	59.1	91.7	122.5	156.1	191.1	227.4	265.0	303.9	344.1	385.6	428.4
10	36.1	72.5	111.4	149.2	189.5	231.2	274.1	318.4	363.9	410.8	459.0	508.5
12	42.4	85.0	130.4	174.3	220.9	268.9	318.1	368.6	420.5	473.7	528.1	583.9
14	46.3	92.9	142.2	190.0	240.6	292.4	345.6	400.1	455.8	512.9	571.3	631.1
16	52.6	105.5	161.1	215.2	272.0	330.1	389.6	450.3	512.4	575.8	640.5	706.4
18	58.9	118.0	179.9	240.3	303.4	367.8	433.6	500.6	568.9	638.6	709.6	781.8
20	65.1	130.6	198.8	265.4	334.8	405.5	477.5	550.9	625.5	701.4	778.7	857.2
22	71.4	143.2	217.6	290.6	366.2	443.2	521.5	601.1	682.0	764.3	847.8	932.6
24	77.7	155.7	236.5	315.7	397.7	480.9	565.5	651.4	738.6	827.1	916.9	1008.0
26	84.0	168.3	255.3	340.8	429.1	518.6	609.5	701.6	795.1	889.9	986.0	1083.4
28	90.3	180.9	274.2	366.0	460.5	556.3	653.5	751.9	851.7	952.8	1055.1	1158.8
30	96.6	193.4	293.0	391.1	491.9	594.0	697.4	802.2	908.2	1015.6	1124.3	1234.2
32	102.8	206.0	311.9	416.2	523.3	631.7	741.4	852.4	964.8	1078.4	1193.4	1309.6
34	109.1	218.6	330.7	441.4	554.7	669.4	785.4	902.7	1021.3	1141.2	1262.5	1385.0
36	115.4	231.1	349.6	466.5	586.2	707.1	829.4	953.0	1077.9	1204.1	1331.6	1460.4
38	121.7	243.7	368.4	491.6	617.6	744.8	873.4	1003.2	1134.4	1266.9	1400.7	1535.8
40	128.0	256.3	387.3	516.8	649.0	782.5	917.4	1053.5	1191.0	1329.7	1469.8	1611.2
42	134.3	268.8	406.1	541.9	680.4	820.2	961.3	1103.8	1247.5	1392.6	1538.9	1686.6
44	140.5	281.4	425.0	567.0	711.8	857.9	1005.3	1154.0	1304.1	1455.4	1608.1	1762.0
46	146.8	294.0	443.8	592.2	743.2	895.6	1049.3	1204.3	1360.6	1518.2	1677.2	1837.4
48	153.1	306.5	462.7	617.3	774.6	933.3	1093.3	1254.6	1417.2	1581.1	1746.3	1912.8

NOTES:

Includes 1 in overlap.

All measurements should be verified with a test piece.

Contact Aspen Aerogels for additional sizes.

Cryogel® Z and Pyrogel® XT/XT-E/XTF 10 mm Blanket Cut Chart (cm)

Material Stretchout (cm)												
NPS (mm)	Number of Layers											
	1	2	3	4	5	6	7	8	9	10	11	12
15	15.8	35.7	62.2	95.3	135.0	181.3	234.2	293.7	359.7	432.4	511.7	597.6
20	17.5	39.1	67.3	102.0	143.4	191.4	245.9	307.1	374.8	449.2	530.1	617.7
25	19.6	43.3	73.6	110.5	154.0	204.0	260.7	324.0	393.9	470.3	553.4	643.1
32	22.4	48.8	81.9	121.5	167.7	220.6	280.0	346.0	418.6	497.9	583.7	676.1
40	24.3	52.7	87.6	129.2	177.3	232.1	293.4	361.3	435.9	517.0	604.7	699.1
50	28.1	60.2	99.0	144.3	196.3	254.8	319.9	391.7	470.0	554.9	646.4	744.6
65	32.1	68.2	110.9	160.3	216.2	278.7	347.9	423.6	505.9	594.8	690.3	792.4
80	37.1	78.2	125.9	180.2	241.1	308.7	382.8	463.5	550.8	644.7	745.2	852.3
90	41.1	86.2	137.9	196.2	261.1	332.6	410.7	495.4	586.7	684.6	789.1	900.2
100	45.0	94.1	149.8	212.1	281.0	356.5	438.6	527.3	622.6	724.5	833.0	948.0
115	49.0	102.1	161.8	228.1	301.0	380.5	466.6	559.2	658.5	764.4	876.8	995.9
125	53.5	111.1	175.3	246.1	323.5	407.4	498.0	595.2	698.9	809.3	926.3	1049.8
150	62.0	128.1	200.7	280.0	365.8	458.3	557.3	663.0	775.2	894.0	1019.5	1151.5
200	78.0	160.0	248.6	343.8	445.6	554.0	669.0	790.6	918.8	1053.6	1195.0	1343.0
250	94.9	193.9	299.5	411.6	530.4	655.8	787.7	926.3	1071.5	1223.2	1381.6	1546.5
300	110.9	225.8	347.3	475.5	610.2	751.5	899.4	1054.0	1215.1	1382.8	1557.1	1738.0
350	120.9	245.8	377.3	515.4	660.1	811.4	969.3	1133.8	1304.9	1482.5	1666.8	1857.7
400	136.8	277.7	425.1	579.2	739.9	907.1	1081.0	1261.4	1448.5	1642.1	1842.4	2049.2
450	152.8	309.6	473.0	643.0	819.7	1002.9	1192.7	1389.1	1592.1	1801.7	2017.9	2240.7
500	168.7	341.5	520.9	706.9	899.5	1098.6	1304.4	1516.8	1735.8	1961.3	2193.5	2432.2
550	184.7	373.4	568.8	770.7	979.3	1194.4	1416.1	1644.5	1879.4	2120.9	2369.0	2623.8
600	200.6	405.4	616.7	834.6	1059.1	1290.2	1527.8	1772.1	2023.0	2280.5	2544.6	2815.3
650	216.6	437.3	664.5	898.4	1138.9	1385.9	1639.6	1899.8	2166.7	2440.1	2720.1	3006.8
700	232.6	469.2	712.4	962.2	1218.7	1481.7	1751.3	2027.5	2310.3	2599.7	2895.7	3198.3
750	248.5	501.1	760.3	1026.1	1298.4	1577.4	1863.0	2155.2	2453.9	2759.3	3071.2	3389.8
800	264.5	533.0	808.2	1089.9	1378.2	1673.2	1974.7	2282.8	2597.6	2918.9	3246.8	3581.3
850	280.4	564.9	856.0	1153.7	1458.0	1768.9	2086.4	2410.5	2741.2	3078.5	3422.4	3772.8
900	296.4	596.9	903.9	1217.6	1537.8	1864.7	2198.1	2538.2	2884.8	3238.1	3597.9	3964.3
950	312.4	628.8	951.8	1281.4	1617.6	1960.4	2309.9	2665.9	3028.5	3397.7	3773.5	4155.9
1000	328.3	660.7	999.7	1345.3	1697.4	2056.2	2421.6	2793.5	3172.1	3557.3	3949.0	4347.4
1050	344.3	692.6	1047.6	1409.1	1777.2	2152.0	2533.3	2921.2	3315.7	3716.8	4124.6	4538.9
1100	360.2	724.5	1095.4	1472.9	1857.0	2247.7	2645.0	3048.9	3459.4	3876.4	4300.1	4730.4
1150	376.2	756.5	1143.3	1536.8	1936.8	2343.5	2756.7	3176.6	3603.0	4036.0	4475.7	4921.9
1200	392.2	788.4	1191.2	1600.6	2016.6	2439.2	2868.4	3304.2	3746.6	4195.6	4651.2	5113.4

NOTES:

Includes 2.5 cm (1 in) overlap.

All measurements should be verified with a test piece.

Note that for best fit on pipes smaller than 100 mm (4 in) NPS, use 5 mm blanket or 10 mm V-groove.

Contact Aspen Aerogels for additional sizes.

Cryogel® Z and Pyrogel® XT/XT-E/XTF 10 mm (0.4 in) Blanket Cut Chart (inches)

Material Stretchout (inches)												
NPS (inches)	Number of Layers											
	1	2	3	4	5	6	7	8	9	10	11	12
0.5	6.2	14.1	24.5	37.5	53.2	71.4	92.2	115.6	141.6	170.2	201.5	235.3
0.75	6.9	15.4	26.5	40.2	56.5	75.3	96.8	120.9	147.6	176.8	208.7	243.2
1	7.7	17.1	29.0	43.5	60.6	80.3	102.6	127.6	155.1	185.2	217.9	253.2
1.25	8.8	19.2	32.2	47.8	66.0	86.8	110.2	136.2	164.8	196.0	229.8	266.2
1.5	9.6	20.7	34.5	50.8	69.8	91.4	115.5	142.3	171.6	203.5	238.1	275.2
2	11.1	23.7	39.0	56.8	77.3	100.3	126.0	154.2	185.0	218.5	254.5	293.1
2.5	12.6	26.9	43.7	63.1	85.1	109.7	137.0	166.8	199.2	234.2	271.8	312.0
3	14.6	30.8	49.6	71.0	94.9	121.5	150.7	182.5	216.8	253.8	293.4	335.5
3.5	16.2	33.9	54.3	77.2	102.8	130.9	161.7	195.0	231.0	269.5	310.7	354.4
4	17.7	37.1	59.0	83.5	110.6	140.4	172.7	207.6	245.1	285.2	327.9	373.2
4.5	19.3	40.2	63.7	89.8	118.5	149.8	183.7	220.2	259.3	300.9	345.2	392.1
5	21.1	43.7	69.0	96.9	127.3	160.4	196.1	234.3	275.2	318.6	364.7	413.3
6	24.4	50.4	79.0	110.2	144.0	180.4	219.4	261.0	305.2	352.0	401.4	453.4
8	30.7	63.0	97.9	135.4	175.4	218.1	263.4	311.3	361.7	414.8	470.5	528.8
10	37.4	76.3	117.9	162.1	208.8	258.2	310.1	364.7	421.8	481.6	543.9	608.9
12	43.7	88.9	136.8	187.2	240.2	295.9	354.1	414.9	478.4	544.4	613.0	684.3
14	47.6	96.8	148.5	202.9	259.9	319.4	381.6	446.4	513.7	583.7	656.2	731.4
16	53.9	109.3	167.4	228.0	291.3	357.1	425.6	496.6	570.3	646.5	725.3	806.8
18	60.1	121.9	186.2	253.2	322.7	394.8	469.6	546.9	626.8	709.3	794.5	882.2
20	66.4	134.5	205.1	278.3	354.1	432.5	513.5	597.2	683.4	772.2	863.6	957.6
22	72.7	147.0	223.9	303.4	385.5	470.2	557.5	647.4	739.9	835.0	932.7	1033.0
24	79.0	159.6	242.8	328.6	417.0	507.9	601.5	697.7	796.5	897.8	1001.8	1108.4
26	85.3	172.2	261.6	353.7	448.4	545.6	645.5	748.0	853.0	960.7	1070.9	1183.8
28	91.6	184.7	280.5	378.8	479.8	583.3	689.5	798.2	909.6	1023.5	1140.0	1259.2
30	97.8	197.3	299.3	404.0	511.2	621.0	733.5	848.5	966.1	1086.3	1209.2	1334.6
32	104.1	209.9	318.2	429.1	542.6	658.7	777.4	898.8	1022.7	1149.2	1278.3	1410.0
34	110.4	222.4	337.0	454.2	574.0	696.4	821.4	949.0	1079.2	1212.0	1347.4	1485.4
36	116.7	235.0	355.9	479.4	605.4	734.1	865.4	999.3	1135.8	1274.8	1416.5	1560.8
38	123.0	247.6	374.7	504.5	636.9	771.8	909.4	1049.5	1192.3	1337.7	1485.6	1636.2
40	129.3	260.1	393.6	529.6	668.3	809.5	953.4	1099.8	1248.9	1400.5	1554.7	1711.6
42	135.5	272.7	412.4	554.8	699.7	847.2	997.4	1150.1	1305.4	1463.3	1623.8	1787.0
44	141.8	285.3	431.3	579.9	731.1	884.9	1041.3	1200.3	1362.0	1526.2	1693.0	1862.4
46	148.1	297.8	450.1	605.0	762.5	922.6	1085.3	1250.6	1418.5	1589.0	1762.1	1937.8
48	154.4	310.4	469.0	630.2	793.9	960.3	1129.3	1300.9	1475.1	1651.8	1831.2	2013.2

NOTES:

Includes 1 in overlap.

All measurements at left should be verified with a test piece.

Note that for best fit on pipes smaller than 4" NPS, use 0.2 in (5 mm) blanket or 0.4 in (10 mm) V-groove.

Contact Aspen Aerogels for additional sizes.

Aerogel Insulation Cladding Cut Chart (mm)

NPS (mm)	Aerogel Thickness (mm)															
	5 mm	10 mm	15 mm	20 mm	25 mm	30 mm	35 mm	40 mm	45 mm	50 mm	55 mm	60 mm	65 mm	70 mm	75 mm	80 mm
	Cladding Cut Length (mm)															
15	149.2	180.7	212.1	243.5	274.9	306.3	337.7	369.2	400.6	432.0	463.4	494.8	526.2	557.7	589.1	620.5
20	166.0	197.4	228.8	260.3	291.7	323.1	354.5	385.9	417.3	448.7	480.2	511.6	543.0	574.4	605.8	637.2
25	187.1	218.6	250.0	281.4	312.8	344.2	375.6	407.1	438.5	469.9	501.3	532.7	564.1	595.6	627.0	658.4
32	214.7	246.1	277.5	308.9	340.3	371.8	403.2	434.6	466.0	497.4	528.8	560.3	591.7	623.1	654.5	685.9
40	233.8	265.2	296.7	328.1	359.5	390.9	422.3	453.7	485.2	516.6	548.0	579.4	610.8	642.2	673.7	705.1
50	271.7	303.1	334.6	366.0	397.4	428.8	460.2	491.6	523.1	554.5	585.9	617.3	648.7	680.1	711.6	743.0
65	311.6	343.0	374.5	405.9	437.3	468.7	500.1	531.5	563.0	594.4	625.8	657.2	688.6	720.0	751.5	782.9
80	361.5	392.9	424.3	455.8	487.2	518.6	550.0	581.4	612.8	644.2	675.7	707.1	738.5	769.9	801.3	832.7
90	401.4	432.8	464.2	495.7	527.1	558.5	589.9	621.3	652.7	684.1	715.6	747.0	778.4	809.8	841.2	872.6
100	441.3	472.7	504.1	535.5	567.0	598.4	629.8	661.2	692.6	724.0	755.5	786.9	818.3	849.7	881.1	912.5
115	481.2	512.6	544.0	575.4	606.9	638.3	669.7	701.1	732.5	763.9	795.4	826.8	858.2	889.6	921.0	952.4
125	526.1	557.5	589.0	620.4	651.8	683.2	714.6	746.0	777.5	808.9	840.3	871.7	903.1	934.5	965.9	997.4
150	610.9	642.3	673.7	705.1	736.5	767.9	799.4	830.8	862.2	893.6	925.0	956.4	987.9	1019.3	1050.7	1082.1
200	770.5	801.9	833.3	864.7	896.1	927.5	959.0	990.4	1021.8	1053.2	1084.6	1116.0	1147.5	1178.9	1210.3	1241.7
250	940.0	971.4	1002.9	1034.3	1065.7	1097.1	1128.5	1159.9	1191.4	1222.8	1254.2	1285.6	1317.0	1348.4	1379.9	1411.3
300	1099.6	1131.0	1162.5	1193.9	1225.3	1256.7	1288.1	1319.5	1351.0	1382.4	1413.8	1445.2	1476.6	1508.0	1539.4	1570.9
350	1199.4	1230.8	1262.2	1293.6	1325.0	1356.4	1387.9	1419.3	1450.7	1482.1	1513.5	1544.9	1576.4	1607.8	1639.2	1670.6
400	1359.0	1390.4	1421.8	1453.2	1484.6	1516.0	1547.5	1578.9	1610.3	1641.7	1673.1	1704.5	1736.0	1767.4	1798.8	1830.2
450	1518.6	1550.0	1581.4	1612.8	1644.2	1675.6	1707.1	1738.5	1769.9	1801.3	1832.7	1864.1	1895.5	1927.0	1958.4	1989.8
500	1678.1	1709.6	1741.0	1772.4	1803.8	1835.2	1866.6	1898.1	1929.5	1960.9	1992.3	2023.7	2055.1	2086.6	2118.0	2149.4
550	1837.7	1869.2	1900.6	1932.0	1963.4	1994.8	2026.2	2057.7	2089.1	2120.5	2151.9	2183.3	2214.7	2246.1	2277.6	2309.0
600	1997.3	2028.8	2060.2	2091.6	2123.0	2154.4	2185.8	2217.2	2248.7	2280.1	2311.5	2342.9	2374.3	2405.7	2437.2	2468.6
650	2156.9	2188.3	2219.8	2251.2	2282.6	2314.0	2345.4	2376.8	2408.3	2439.7	2471.1	2502.5	2533.9	2565.3	2596.8	2628.2
700	2316.5	2347.9	2379.4	2410.8	2442.2	2473.6	2505.0	2536.4	2567.8	2599.3	2630.7	2662.1	2693.5	2724.9	2756.3	2787.8
750	2476.1	2507.5	2538.9	2570.4	2601.8	2633.2	2664.6	2696.0	2727.4	2758.9	2790.3	2821.7	2853.1	2884.5	2915.9	2947.4
800	2635.7	2667.1	2698.5	2730.0	2761.4	2792.8	2824.2	2855.6	2887.0	2918.5	2949.9	2981.3	3012.7	3044.1	3075.5	3106.9
850	2795.3	2826.7	2858.1	2889.5	2921.0	2952.4	2983.8	3015.2	3046.6	3078.0	3109.5	3140.9	3172.3	3203.7	3235.1	3266.5
900	2954.9	2986.3	3017.7	3049.1	3080.6	3112.0	3143.4	3174.8	3206.2	3237.6	3269.1	3300.5	3331.9	3363.3	3394.7	3426.1
950	3114.5	3145.9	3177.3	3208.7	3240.2	3271.6	3303.0	3334.4	3365.8	3397.2	3428.6	3460.1	3491.5	3522.9	3554.3	3585.7
1000	3274.1	3305.5	3336.9	3368.3	3399.7	3431.2	3462.6	3494.0	3525.4	3556.8	3588.2	3619.7	3651.1	3682.5	3713.9	3745.3
1050	3433.7	3465.1	3496.5	3527.9	3559.3	3590.8	3622.2	3653.6	3685.0	3716.4	3747.8	3779.2	3810.7	3842.1	3873.5	3904.9
1100	3593.3	3624.7	3656.1	3687.5	3718.9	3750.3	3781.8	3813.2	3844.6	3876.0	3907.4	3938.8	3970.3	4001.7	4033.1	4064.5
1150	3752.9	3784.3	3815.7	3847.1	3878.5	3909.9	3941.4	3972.8	4004.2	4035.6	4067.0	4098.4	4129.9	4161.3	4192.7	4224.1
1200	3912.5	3943.9	3975.3	4006.7	4038.1	4069.5	4100.9	4132.4	4163.8	4195.2	4226.6	4258.0	4289.4	4320.9	4352.3	4383.7

NOTES:

Areas shaded in grey indicate a finished diameter less than 75 mm. Depending on equipment, rolling metal to a finished diameter less than 75 mm may be problematic. Contact Aspen Aerogels for recommended solutions.

All cut lengths are based on a 50 mm overlap and do not include for safety edge. Additional amounts required for larger overlap or safety edge should be added.

All measurements at left should be verified with a test piece.

Contact Aspen Aerogels for additional sizes.

Aerogel Insulation Cladding Cut Chart (inches)

		Aerogel Thickness (inches)														
NPS (inches)	Cladding Cut Length (inches)															
	0.2 in.	0.4 in.	0.6 in.	0.8 in.	1.0 in.	1.2 in.	1.4 in.	1.6 in.	1.8 in.	2.0 in.	2.2 in.	2.4 in.	2.6 in.	2.8 in.	3.0 in.	3.2 in.
0.5	5.9	7.1	8.3	9.6	10.8	12.1	13.3	14.5	15.8	17.0	18.2	19.5	20.7	22.0	23.2	24.4
0.75	6.5	7.8	9.0	10.2	11.5	12.7	14.0	15.2	16.4	17.7	18.9	20.1	21.4	22.6	23.9	25.1
1	7.4	8.6	9.8	11.1	12.3	13.6	14.8	16.0	17.3	18.5	19.7	21.0	22.2	23.4	24.7	25.9
1.25	8.5	9.7	10.9	12.2	13.4	14.6	15.9	17.1	18.3	19.6	20.8	22.1	23.3	24.5	25.8	27.0
1.5	9.2	10.4	11.7	12.9	14.2	15.4	16.6	17.9	19.1	20.3	21.6	22.8	24.0	25.3	26.5	27.8
2	10.7	11.9	13.2	14.4	15.6	16.9	18.1	19.4	20.6	21.8	23.1	24.3	25.5	26.8	28.0	29.3
2.5	12.3	13.5	14.7	16.0	17.2	18.5	19.7	20.9	22.2	23.4	24.6	25.9	27.1	28.3	29.6	30.8
3	14.2	15.5	16.7	17.9	19.2	20.4	21.7	22.9	24.1	25.4	26.6	27.8	29.1	30.3	31.5	32.8
3.5	15.8	17.0	18.3	19.5	20.8	22.0	23.2	24.5	25.7	26.9	28.2	29.4	30.6	31.9	33.1	34.4
4	17.4	18.6	19.8	21.1	22.3	23.6	24.8	26.0	27.3	28.5	29.7	31.0	32.2	33.5	34.7	35.9
4.5	18.9	20.2	21.4	22.7	23.9	25.1	26.4	27.6	28.8	30.1	31.3	32.6	33.8	35.0	36.3	37.5
5	20.7	22.0	23.2	24.4	25.7	26.9	28.1	29.4	30.6	31.8	33.1	34.3	35.6	36.8	38.0	39.3
6	24.0	25.3	26.5	27.8	29.0	30.2	31.5	32.7	33.9	35.2	36.4	37.7	38.9	40.1	41.4	42.6
8	30.3	31.6	32.8	34.0	35.3	36.5	37.8	39.0	40.2	41.5	42.7	43.9	45.2	46.4	47.6	48.9
10	37.0	38.2	39.5	40.7	42.0	43.2	44.4	45.7	46.9	48.1	49.4	50.6	51.9	53.1	54.3	55.6
12	43.3	44.5	45.8	47.0	48.2	49.5	50.7	52.0	53.2	54.4	55.7	56.9	58.1	59.4	60.6	61.8
14	47.2	48.5	49.7	50.9	52.2	53.4	54.6	55.9	57.1	58.4	59.6	60.8	62.1	63.3	64.5	65.8
16	53.5	54.7	56.0	57.2	58.4	59.7	60.9	62.2	63.4	64.6	65.9	67.1	68.3	69.6	70.8	72.1
18	59.8	61.0	62.3	63.5	64.7	66.0	67.2	68.4	69.7	70.9	72.2	73.4	74.6	75.9	77.1	78.3
20	66.1	67.3	68.5	69.8	71.0	72.3	73.5	74.7	76.0	77.2	78.4	79.7	80.9	82.1	83.4	84.6
22	72.4	73.6	74.8	76.1	77.3	78.5	79.8	81.0	82.2	83.5	84.7	86.0	87.2	88.4	89.7	90.9
24	78.6	79.9	81.1	82.3	83.6	84.8	86.1	87.3	88.5	89.8	91.0	92.2	93.5	94.7	96.0	97.2
26	84.9	86.2	87.4	88.6	89.9	91.1	92.3	93.6	94.8	96.0	97.3	98.5	99.8	101.0	102.2	103.5
28	91.2	92.4	93.7	94.9	96.1	97.4	98.6	99.9	101.1	102.3	103.6	104.8	106.0	107.3	108.5	109.8
30	97.5	98.7	100.0	101.2	102.4	103.7	104.9	106.1	107.4	108.6	109.9	111.1	112.3	113.6	114.8	116.0
32	103.8	105.0	106.2	107.5	108.7	110.0	111.2	112.4	113.7	114.9	116.1	117.4	118.6	119.8	121.1	122.3
34	110.1	111.3	112.5	113.8	115.0	116.2	117.5	118.7	119.9	121.2	122.4	123.7	124.9	126.1	127.4	128.6
36	116.3	117.6	118.8	120.0	121.3	122.5	123.8	125.0	126.2	127.5	128.7	129.9	131.2	132.4	133.7	134.9
38	122.6	123.9	125.1	126.3	127.6	128.8	130.0	131.3	132.5	133.7	135.0	136.2	137.5	138.7	139.9	141.2
40	128.9	130.1	131.4	132.6	133.8	135.1	136.3	137.6	138.8	140.0	141.3	142.5	143.7	145.0	146.2	147.5
42	135.2	136.4	137.7	138.9	140.1	141.4	142.6	143.8	145.1	146.3	147.6	148.8	150.0	151.3	152.5	153.7
44	141.5	142.7	143.9	145.2	146.4	147.7	148.9	150.1	151.4	152.6	153.8	155.1	156.3	157.5	158.8	160.0
46	147.8	149.0	150.2	151.5	152.7	153.9	155.2	156.4	157.6	158.9	160.1	161.4	162.6	163.8	165.1	166.3
48	154.0	155.3	156.5	157.7	159.0	160.2	161.5	162.7	163.9	165.2	166.4	167.6	168.9	170.1	171.3	172.6

NOTES:

Areas shaded in grey indicate a finished diameter less than 3". Depending on equipment, rolling metal to a finished diameter less than 3" may be problematic. Contact Aspen Aerogels for recommended solutions.

All cut lengths are based on a 2" overlap and do not include for safety edge. Additional amounts required for larger overlap of safety should be added.

All measurements at left should be verified with a test piece.

Contact Aspen Aerogels for additional sizes.

Aerogel Miter Cut Chart (mm)

Aerogel Thickness															
NPS (mm)	10 mm			20 mm			30 mm			40 mm			50 mm		
	Heel (mm)	Gores	Throat (mm)	Heel (mm)	Gores	Throat (mm)	Heel (mm)	Gores	Throat (mm)	Heel (mm)	Gores	Throat (mm)	Heel (mm)	Gores	Throat (mm)
100	86.2	4	33.5	90.1	4	29.6	94.1	4	25.6	98.0	4	21.7	101.9	4	17.8
125	106.5	4	43.1	110.4	4	39.2	114.3	4	35.3	118.3	4	31.4	122.2	4	27.4
150	84.5	6	35.2	87.1	6	32.6	89.7	6	30.0	92.3	6	27.3	95.0	6	24.7
200	111.1	6	48.5	113.7	6	45.9	116.3	6	43.3	118.9	6	40.6	121.6	6	38.0
250	103.6	8	46.0	105.5	8	44.1	107.5	8	42.1	109.5	8	40.1	111.4	8	38.2
300	123.5	8	56.0	125.5	8	54.1	127.5	8	52.1	129.4	8	50.1	131.4	8	48.2
350	113.3	10	54.3	114.9	10	52.7	116.4	10	51.1	118.0	10	49.6	119.6	10	48.0
400	129.2	10	62.3	130.8	10	60.7	132.4	10	59.1	134.0	10	57.6	135.5	10	56.0
450	121.0	12	58.5	122.3	12	57.2	123.6	12	55.9	124.9	12	54.6	126.2	12	53.3
500	134.3	12	65.2	135.6	12	63.9	136.9	12	62.6	138.2	12	61.3	139.5	12	60.0
550	126.5	14	61.6	127.6	14	60.5	128.8	14	59.3	129.9	14	58.2	131.0	14	57.1
600	137.9	14	67.3	139.0	14	66.2	140.2	14	65.0	141.3	14	63.9	142.4	14	62.8
650	149.3	14	73.0	150.4	14	71.9	151.6	14	70.7	152.7	14	69.6	153.8	14	68.5
700	140.6	16	68.8	141.6	16	67.9	142.6	16	66.9	143.6	16	65.9	144.6	16	64.9
750	150.6	16	73.8	151.6	16	72.8	152.6	16	71.9	153.5	16	70.9	154.5	16	69.9
800	142.7	18	70.1	143.6	18	69.2	144.5	18	68.3	145.4	18	67.4	146.2	18	66.6
850	151.6	18	74.5	152.5	18	73.6	153.3	18	72.7	154.2	18	71.9	155.1	18	71.0
900	144.4	20	71.0	145.2	20	70.2	146.0	20	69.5	146.8	20	68.7	147.6	20	67.9
950	152.4	20	75.0	153.2	20	74.2	154.0	20	73.5	154.8	20	72.7	155.5	20	71.9
1000	160.4	20	79.0	161.2	20	78.2	161.9	20	77.4	162.7	20	76.7	163.5	20	75.9
1050	168.4	20	83.0	169.1	20	82.2	169.9	20	81.4	170.7	20	80.6	171.5	20	79.9
1100	176.3	20	87.0	177.1	20	86.2	177.9	20	85.4	178.7	20	84.6	179.5	20	83.8
1150	184.3	20	91.0	185.1	20	90.2	185.9	20	89.4	186.7	20	88.6	187.5	20	87.8
1200	192.3	20	95.0	193.1	20	94.2	193.9	20	93.4	194.7	20	92.6	195.4	20	91.8

NOTES:

All measurements above should be verified with a test piece.

Contact Aspen Aerogels for additional sizes.

Aerogel Miter Cut Chart (mm) cont.

Aerogel Thickness															
NPS (mm)	60 mm			70 mm			80 mm			90 mm			100 mm		
	Heel (mm)	Gores	Throat (mm)	Heel (mm)	Gores	Throat (mm)	Heel (mm)	Gores	Throat (mm)	Heel (mm)	Gores	Throat (mm)	Heel (mm)	Gores	Throat (mm)
100	86.2	4	13.8	109.8	4	9.9	113.7	4	6.0	117.6	4	2.1	121.6	4	-1.9
125	126.1	4	23.5	130.0	4	19.6	134.0	4	15.6	137.9	4	11.7	141.8	4	7.8
150	97.6	6	22.1	100.2	6	19.5	102.8	6	16.9	105.4	6	14.3	108.1	6	11.6
200	124.2	6	35.4	126.8	6	32.8	129.4	6	30.2	132.0	6	27.6	134.7	6	24.9
250	113.4	8	36.2	115.4	8	34.3	117.3	8	32.3	119.3	8	30.3	121.3	8	28.4
300	133.3	8	46.2	135.3	8	44.2	137.3	8	42.3	139.2	8	40.3	141.2	8	38.3
350	121.1	10	46.4	122.7	10	44.9	124.3	10	43.3	125.9	10	41.7	127.4	10	40.1
400	137.1	10	54.4	138.7	10	52.8	140.2	10	51.3	141.8	10	49.7	143.4	10	48.1
450	127.5	12	52.0	128.9	12	50.7	130.2	12	49.4	131.5	12	48.1	132.8	12	46.8
500	140.8	12	58.6	142.2	12	57.3	143.5	12	56.0	144.8	12	54.7	146.1	12	53.4
550	132.1	14	56.0	133.2	14	54.8	134.4	14	53.7	135.5	14	52.6	136.6	14	51.5
600	143.5	14	61.7	144.6	14	60.5	145.8	14	59.4	146.9	14	58.3	148.0	14	57.2
650	154.9	14	67.4	156.0	14	66.2	157.2	14	65.1	158.3	14	64.0	159.4	14	62.9
700	145.5	16	63.9	146.5	16	62.9	147.5	16	62.0	148.5	16	61.0	149.5	16	60.0
750	155.5	16	68.9	156.5	16	67.9	157.5	16	67.0	158.5	16	66.0	159.4	16	65.0
800	147.1	18	65.7	148.0	18	64.8	148.8	18	63.9	149.7	18	63.1	150.6	18	62.2
850	156.0	18	70.1	156.8	18	69.3	157.7	18	68.4	158.6	18	67.5	159.5	18	66.6
900	148.3	20	67.1	149.1	20	66.3	149.9	20	65.5	150.7	20	64.7	151.5	20	64.0
950	156.3	20	71.1	157.1	20	70.3	157.9	20	69.5	158.7	20	68.7	159.5	20	68.0
1000	164.3	20	75.1	165.1	20	74.3	165.9	20	73.5	166.7	20	72.7	167.4	20	71.9
1050	172.3	20	79.1	173.1	20	78.3	173.9	20	77.5	174.6	20	76.7	175.4	20	75.9
1100	180.3	20	83.1	181.1	20	82.3	181.8	20	81.5	182.6	20	80.7	183.4	20	79.9
1150	188.2	20	87.1	189.0	20	86.3	189.8	20	85.5	190.6	20	84.7	191.4	20	83.9
1200	196.2	20	91.0	197.0	20	90.3	197.8	20	89.5	198.6	20	88.7	199.4	20	87.9

NOTES:

All measurements above should be verified with a test piece.

Contact Aspen Aerogels for additional sizes.

Aerogel Miter Cut Chart (inches)

Aerogel Thickness																
NPS (inches)	0.4" (10 mm)			0.8" (20 mm)			1.2" (30 mm)			1.6" (40 mm)			2.0" (50 mm)			
	Heel (in.)	Gores	Throat (in.)	Heel (in.)	Gores	Throat (in.)	Heel (in.)	Gores	Throat (in.)	Heel (in.)	Gores	Throat (in.)	Heel (in.)	Gores	Throat (in.)	
4	3.4	4	1.3	3.5	4	1.2	3.7	4	1.0	3.9	4	0.9	4.0	4	0.7	
5	4.2	4	1.7	4.3	4	1.5	4.5	4	1.4	4.7	4	1.2	4.8	4	1.1	
6	3.3	6	1.4	3.4	6	1.3	3.5	6	1.2	3.6	6	1.1	3.7	6	1.0	
8	4.4	6	1.9	4.5	6	1.8	4.6	6	1.7	4.7	6	1.6	4.8	6	1.5	
10	4.1	8	1.8	4.2	8	1.7	4.2	8	1.7	4.3	8	1.6	4.4	8	1.5	
12	4.9	8	2.2	4.9	8	2.1	5.0	8	2.1	5.1	8	2.0	5.2	8	1.9	
14	4.5	10	2.1	4.5	10	2.1	4.6	10	2.0	4.6	10	2.0	4.7	10	1.9	
16	5.1	10	2.5	5.2	10	2.4	5.2	10	2.3	5.3	10	2.3	5.3	10	2.2	
18	4.8	12	2.3	4.8	12	2.3	4.9	12	2.2	4.9	12	2.2	5.0	12	2.1	
20	5.3	12	2.6	5.3	12	2.5	5.4	12	2.5	5.4	12	2.4	5.5	12	2.4	
22	5.0	14	2.4	5.0	14	2.4	5.1	14	2.3	5.1	14	2.3	5.2	14	2.2	
24	5.4	14	2.6	5.5	14	2.6	5.5	14	2.6	5.6	14	2.5	5.6	14	2.5	
26	5.9	14	2.9	5.9	14	2.8	6.0	14	2.8	6.0	14	2.7	6.1	14	2.7	
28	5.5	16	2.7	5.6	16	2.7	5.6	16	2.6	5.7	16	2.6	5.7	16	2.6	
30	5.9	16	2.9	6.0	16	2.9	6.0	16	2.8	6.0	16	2.8	6.1	16	2.8	
32	5.6	18	2.8	5.7	18	2.7	5.7	18	2.7	5.7	18	2.7	5.8	18	2.6	
34	6.0	18	2.9	6.0	18	2.9	6.0	18	2.9	6.1	18	2.8	6.1	18	2.8	
36	5.7	20	2.8	5.7	20	2.8	5.7	20	2.7	5.8	20	2.7	5.8	20	2.7	
38	6.0	20	3.0	6.0	20	2.9	6.1	20	2.9	6.1	20	2.9	6.1	20	2.8	
40	6.3	20	3.1	6.3	20	3.1	6.4	20	3.0	6.4	20	3.0	6.4	20	3.0	
42	6.6	20	3.3	6.7	20	3.2	6.7	20	3.2	6.7	20	3.2	6.8	20	3.1	
44	6.9	20	3.4	7.0	20	3.4	7.0	20	3.4	7.0	20	3.3	7.1	20	3.3	
46	7.3	20	3.6	7.3	20	3.6	7.3	20	3.5	7.3	20	3.5	7.4	20	3.5	
48	7.6	20	3.7	7.6	20	3.7	7.6	20	3.7	7.7	20	3.6	7.7	20	3.6	

NOTES:

All measurements above should be verified with a test piece.

Contact Aspen Aerogels for additional sizes.

Aerogel Miter Cut Chart (inches) cont.

Aerogel Thickness																
NPS (inches)	2.4" (60 mm)			2.8" (70 mm)			3.2" (80 mm)			3.6" (90 mm)			4.0" (100 mm)			
	Heel (in.)	Gores	Throat (in.)	Heel (in.)	Gores	Throat (in.)	Heel (in.)	Gores	Throat (in.)	Heel (in.)	Gores	Throat (in.)	Heel (in.)	Gores	Throat (in.)	
4	3.4	4	0.5	4.3	4	0.4	4.5	4	0.2	4.6	4	0.1	4.8	4	-0.1	
5	5.0	4	0.9	5.1	4	0.8	5.3	4	0.6	5.4	4	0.5	5.6	4	0.3	
6	3.8	6	0.9	3.9	6	0.8	4.0	6	0.7	4.2	6	0.6	4.3	6	0.5	
8	4.9	6	1.4	5.0	6	1.3	5.1	6	1.2	5.2	6	1.1	5.3	6	1.0	
10	4.5	8	1.4	4.5	8	1.3	4.6	8	1.3	4.7	8	1.2	4.8	8	1.1	
12	5.2	8	1.8	5.3	8	1.7	5.4	8	1.7	5.5	8	1.6	5.6	8	1.5	
14	4.8	10	1.8	4.8	10	1.8	4.9	10	1.7	5.0	10	1.6	5.0	10	1.6	
16	5.4	10	2.1	5.5	10	2.1	5.5	10	2.0	5.6	10	2.0	5.6	10	1.9	
18	5.0	12	2.0	5.1	12	2.0	5.1	12	1.9	5.2	12	1.9	5.2	12	1.8	
20	5.5	12	2.3	5.6	12	2.3	5.6	12	2.2	5.7	12	2.2	5.8	12	2.1	
22	5.2	14	2.2	5.2	14	2.2	5.3	14	2.1	5.3	14	2.1	5.4	14	2.0	
24	5.7	14	2.4	5.7	14	2.4	5.7	14	2.3	5.8	14	2.3	5.8	14	2.3	
26	6.1	14	2.7	6.1	14	2.6	6.2	14	2.6	6.2	14	2.5	6.3	14	2.5	
28	5.7	16	2.5	5.8	16	2.5	5.8	16	2.4	5.8	16	2.4	5.9	16	2.4	
30	6.1	16	2.7	6.2	16	2.7	6.2	16	2.6	6.2	16	2.6	6.3	16	2.6	
32	5.8	18	2.6	5.8	18	2.6	5.9	18	2.5	5.9	18	2.5	5.9	18	2.4	
34	6.1	18	2.8	6.2	18	2.7	6.2	18	2.7	6.2	18	2.7	6.3	18	2.6	
36	5.8	20	2.6	5.9	20	2.6	5.9	20	2.6	5.9	20	2.5	6.0	20	2.5	
38	6.2	20	2.8	6.2	20	2.8	6.2	20	2.7	6.2	20	2.7	6.3	20	2.7	
40	6.5	20	3.0	6.5	20	2.9	6.5	20	2.9	6.6	20	2.9	6.6	20	2.8	
42	6.8	20	3.1	6.8	20	3.1	6.8	20	3.1	6.9	20	3.0	6.9	20	3.0	
44	7.1	20	3.3	7.1	20	3.2	7.2	20	3.2	7.2	20	3.2	7.2	20	3.1	
46	7.4	20	3.4	7.4	20	3.4	7.5	20	3.4	7.5	20	3.3	7.5	20	3.3	
48	7.7	20	3.6	7.8	20	3.6	7.8	20	3.5	7.8	20	3.5	7.8	20	3.5	

NOTES:

All measurements above should be verified with a test piece.

Contact Aspen Aerogels for additional sizes.

For specialized training or recommendations regarding our application procedures, call 508-691-1111, visit info.aerogel.com/contact, or scan below with mobile device QR reader.

